



TRANE®

Air Cooled Liquid Chiller With Centrifugal Fans

**CGCL 200 - 250 - 300 - 350 - 400 - 450 -
500 - 600**
**with CH530 Adaptive Control™ chiller
controller**



CG-PRC009-E4



Contents

Features and benefits	3
Application considerations	7
Controls	9
General Data	15
Condenser fan performances	16
Pressure drop through condenser coil and air filter	17
Performance data	18
Mechanical specifications	23

Features and benefits

Air-cooled liquid chillers with centrifugal fans: Unique product feature and advantage for installations where a traditional air-cooled chiller does not fit

Traditionally, air-cooled liquid chillers have propeller fans and are designed for outdoor installations with enough space around to ensure a proper airflow through the condenser and also with no constraints on the fan discharge side.

Air-cooled liquid chillers with centrifugal fans are designed for installation inside the building. These chillers have several distinct advantages: wide application flexibility and generally a lower life cycle cost than air-cooled chillers with propeller fans.

The CGCL centrifugal fan indoor air-cooled chiller is the right solution for:

- Floor-by-floor air conditioning systems with individual metering and billing.
- Critical, noise-sensitive installations allowing the use of silencers (hidden indoor installation eliminates neighborhood complaints).
- Areas with heavy air pollution. Investments are protected thanks to indoor installation.
- A ductable condenser air intake. The condenser air inlet is located on one side of the unit which makes it possible to isolate the machine room from low outdoor air temperatures.
- An alternative to a remote evaporator solution. The evaporator is situated out of the condenser air stream. When the unit is shut down during the cold season, the air circulation inside the condenser section is not in contact with the evaporator which is then totally protected from freezing.

Available external static pressure

Available static pressure allows the use of long ducts and the installation of silencers.

Units may be used as exhaust fans, taking advantage of the cooler building exhaust air to increase the cooling capacity and/or reducing kW-consumption. During the cold season, the condenser exhaust air can be used for space heating.

Features and benefits

Mounting on site

The compact size of the CGCL simplifies the installation on site and its low wide profile allows it to pass easily through a door. The total area taken up by the unit is relatively small due to the reduced size. rubber pads are supplied as standard to avoid direct contact between the unit base and the mounting surface.

Water connections

The water connections are brought to the outside of the unit so that it is not necessary to remove or pierce the panels.

Electrical connections

Electrical cable gland located on the left side of the panel allow for easy connection of the power cable.

A flow detection system is mounted as standard in the factory. It is therefore not necessary to fit a Flow Switch on site.

A dry contact is available on the control module to control the water pump contactor. Water pump contactor can be installed by Trane as an option.

Features and benefits

Reliable and quiet operation

Reliability

The use of the Scroll compressors ensures excellent reliability. Versus a reciprocating compressor, the Scroll has the following advantages.

- 64 % fewer parts.
- The Scroll compressor generates significantly less vibration therefore reducing the risk of discharge line failure.

Performance

The absence of dead volume at the end of the compression cycle ensures better performance.

The absence of fragile moving parts, such as springs and valves, also means that this performance is maintained with time.

Part load performance

The Scroll compressor always operates at full load.

The chiller capacity is a function of the number of compressors running. CGCL provides as many capacity steps as number of compressors, which means that each compressor has its dedicated on/off contactor. In this way the power factor is maintained at a high level even at low loads.

Low sound level

The Scroll compressor is significantly less noisy and generates less vibration than a reciprocating compressor. In addition, on sites where the noise level is critical, the compressors can be fitted with an optional sound attenuating enclosure.

Reduced maintenance

The Scroll compressor does not require routine maintenance due to the absence of fragile parts, such as springs and valves which require regular replacement.

Features and benefits

Other standard features

- Thermal insulation of the water connections, and of the evaporator.
- Loss of water flow protection provided by a flow switch.
- Operation up to + 40°C external temperature.
- Shipped with rubber pads.
- Centrifugal fans which allow to obtain a static pressure up to 500 Pa.
- A resistance heater placed on the evaporator to avoid freeze-up risk. The heater is energized only if the external temperature is below + 2°C.
- Pressure transducers to obtain an optimal control of the fans and to allow to display the low and high refrigerant pressure.
- Modem connection.
- Electrical panel IP 55.

Application considerations

Application of this product should be within the catalogued waterflow and performance consideration.

Clearance requirements

The recommended clearances identified with unit dimensions should be maintained to assure adequate serviceability, maximum capacity and peak operating efficiency. Actual clearances that appear inadequate should be reviewed with the local TRANE representative. Submittals drawings are available on request.

Operating limits.

Table 1 - Operating limits R 407C

Min. outdoor air temperature - Std/Low ambient	-5°C/-18°C
Max. outdoor air temperature	+ 40°C
Min. leaving water temperature	-12°C (37% glycol)
Max. leaving water temperature	+ 12°C

Condenser fan configuration

Figure 1 - Fan arrangement

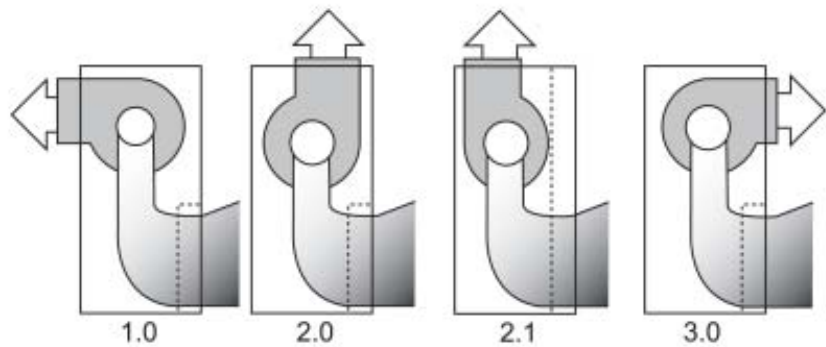

Table 2

Unit	Configuration nbr			
	1.0	2.0	2.1	3.0
CGCL 200	Yes	Yes	No	Yes
CGCL 250	Yes	Yes	No	Yes
CGCL 300	Yes	Yes	No	Yes
CGCL 350	Yes	Yes	No	Yes
CGCL 400	Yes	Yes	No	Yes
CGCL 450	Yes	Yes	No	Yes
CGCL 500	Yes	Yes	Yes	No
CGCL 600	Yes	Yes	Yes	No

Application considerations

Minimum installation water content

The water volume is an important parameter because it allows a stable chilled water temperature and avoids short cycle operation of the compressors.

Parameters which influence the water temperature stability

- Ambient temperature and water temperature (modify cooling capacity)
- Number of capacity steps.
- Minimum time between two starts of a compressor.
- Water loop volume.
- Load fluctuations.
- The percentage of glycol.
- Dead band (adjusted by control).

Note: On CGCL, there are as many steps as there are compressors.

Minimum water volume for a comfort application

For comfort applications we can allow limited water temperature fluctuation. The parameter to take into account is the minimum operating time of the compressors. To avoid lubrication problems on a scroll compressor, it must run at least 120 seconds before it stops. The CH530 control, thanks to its unique Adaptive Control™ capability, will adjust the dead band to your water loop to guarantee cooling production.

See Table 3 for recommended water loop content for most comfort applications.

For specific applications or for additional information, contact your local Trane Sales Office.

Table 3 - Recommended water loop volume at Eurovent conditions

	Unit size	200	250	300	350	400	450	500	600
Chiller data	Cooling Capacity full load (kW)	49.2	61.1	74.0	86.9	101.0	111.0	126.0	152.0
	Biggest step (%)	50	60	50	43	38	33	30	25
	Biggest step (kW)	24.6	36.7	37.0	37.2	37.9	36.6	37.8	38.0
Minimum water loop for comfort application (l)		235	351	354	356	363	350	362	364

This table is estimated with : 35°C ambient air temperature, 12/7°C water temperature, water (no glycol), deadband of 3°C.

Controls

Figure 2 - DynaView operator interface



Human Interfaces

DynaView is an LCD touchscreen display (Figure 2) that is navigated by file tabs. This is an advanced interface that allows the user to access any important information concerning setpoints, active temperatures, modes, electrical data, pressures, and diagnostics. It uses full text display available in 15 languages.

Adaptive Safety Controls

A centralised microcomputer offers a higher level of machine protection. Since the safety controls are smarter, they limit compressor operation to avoid compressor or evaporator failures, thereby minimizing nuisance shutdown. Tracer™ Chiller Controls directly senses the control variables that govern the operation of the chiller: motor current draw, evaporator pressure and condenser pressure. When any one of these variables approaches a limit condition where damage may occur to the unit or shutdown on a safety, Tracer Chiller Controls takes corrective action to avoid shutdown and keep the chiller operating. This happens through combined actions of compressor stage modulation and fan staging. Tracer Chiller Controls optimises total chiller power consumption during normal operating conditions. During abnormal operating conditions, the microprocessor will continue to optimise chiller performance by taking the corrective action necessary to avoid shutdown. This keeps cooling capacity available until the problem can be solved. Whenever possible, the chiller is allowed to perform its function; making chilled water. In addition, microcomputer controls allow for more types of protection such as phase reversal protection. Overall, the safety controls help keep the building or process running and out of trouble.

Controls

Stand-alone controls

Interfacing to stand-alone units is very simple: only a remote auto/stop for scheduling is required for unit operation. Signals from the chilled-water pump contactor auxiliary, or a flow switch, are wired to the chilled-water flow interlock. Signals from a time clock or some other remote device are wired to the external auto/stop input.

Standard Features External

Auto/Stop

A job-site-provided contact closure will turn the unit on and off.

Chilled Waterflow Interlock

Unit is equipped with a water flow control, it will allow unit operation if a load exists. This feature will allow the unit to run in conjunction with the pump system.

External Interlock

A job-site-provided contact opening wired to this input will turn the unit off and require a manual reset of the unit microcomputer. This closure is typically triggered by a job-site provided system such as a fire alarm.

Chilled Water Pump Control

Controls can provide an output to control the external chilled-water pump(s).

One contact closure to the chiller is all that is required to initiate the chilled-water system.

Additional Features that May Be Added (require some optional factory-installed hardware)

- Ice-making card
- LON communication card
- Temperature display, compressor kW inhibit, setpoint reset, external setpoint, auxiliary setpoint.
- Customer report relay (alarm latching, alarm auto reset, chiller running, Chiller at full load)

Easy Interface to a Generic Building Management System

Controlling the AquaStream2® chillers with building management systems is state-of-the-art, yet simple with either:

- the LonTalk Communications Interface for Chillers (LCI-C)
- or Generic Building Management System Hardwire Points.

Simple Interface with Other Control Systems

Microcomputer controls afford simple interface with other control systems, such as time clocks, building automation systems, and ice storage systems. This means you have the flexibility to meet job requirements while not having to learn a complicated control system.

This setup has the same standard features as a stand-alone water chiller, with the possibility of having additional optional features.

Controls

What are LonTalk, Echelon, and LonMark?

LonTalk is a communications protocol developed by the Echelon Corporation. The LonMark association develops control profiles using the LonTalk communication protocol. LonTalk is a unit level communications protocol, unlike BACNet used at the system level.

LonTalk Communications Interface for Chillers (LCI-C)

LonTalk Communications Interface for Chillers (LCI-C) provides a generic automation system with the LonMark chiller profile inputs/outputs. The inputs/ outputs include both mandatory and optional network variables.

Note: LonMark network variable names are in parentheses when different from chiller naming convention.

Chiller Inputs:

- Chiller Enable/Disable
- Ice Making (Chiller Mode)
- External setpoint or kW limitation setpoint
- Unit emergency stop report
- Auxiliary setpoint enable

Chiller Enable/Disable

Allows for chiller to be started or stopped depending on if certain operating conditions are met.

Ice Making

Provides interface with ice making control systems.

External setpoint or kW limitation setpoint

Allow to modify, remotely, the setpoints of the unit:

- By modifying the water leaving temperature setpoint of the unit,
- Or by limiting the load of the unit thus the electrical input.

Chiller Outputs:

- On/Off
- Active Setpoint
- Leaving Chilled Water Temperature
- Entering Chilled Water Temperature
- Alarm Descriptor
- Chiller Status

On/Off

Indicates the current state of the chiller

Active Setpoint

Indicates the current value of the leaving water temperature setpoint

Controls

Leaving Chilled Water Temperature

Provides the current leaving water temperature

Entering Chilled Water Temperature

Provides the current entering water temperature.

Alarm Descriptor

Provides alarm messages based on predetermined criteria

Chiller Status

Indicates the running modes and states of the chiller, i.e. Running in alarm mode, chiller enabled, chiller being locally controlled, etc...

Generic Building Management System Hardwire Points

GBAS may be achieved via hardware input/output as well.

The input/outputs are as follows:

Chiller hardware inputs include:

- Chiller enable/disable
- External chilled water setpoint - (Optional feature)
- Ice making enable - (Optional feature)

External Chilled Water Setpoint - (Optional feature)

Allows the external setting independent of the front panel setpoint by one of two means:

1. 2-10 VDC input, or
2. 4-20 mA input

Chiller hardware outputs include:

- Compressor running indication
- Alarm indication (Ckt 1/Ckt 2)
- Maximum capacity
- Ice making status

Alarm Indication Contacts

The unit provides three single-pole/double-throw contact closures to indicate:

1. Compressor on/off status
2. Compressor running at maximum capacity
3. Failure has occurred (Ckt 1/Ckt 2)

These contact closures may be used to trigger job site supplied alarm lights or alarm bells.

Ice Making Control - (Optional feature)

Provides interface with ice making control systems.

Controls

Tracer Summit™ Controls - Interface with the Trane Integrated Comfort System (ICS)

Trane Chiller Plant Control

The Tracer Chiller Plant Manager building management system provides building automation and energy management functions through stand-alone control. The Chiller Plant Control is capable of monitoring and controlling your entire chiller plant system.

Application software available:

- Process control language
- Boolean processing
- Zone control
- Reports and logs
- Custom messages
- Run time and maintenance
- Trend log
- PID control loops

And of course, the Trane Chiller Plant Control can be used on a stand-alone basis or tied into a complete building automation system. When the air-cooled chiller is used in conjunction with a Trane Tracer Summit™ system, the unit can be monitored and controlled from a remote location.

The air-cooled chiller can be controlled to fit into the overall building automation strategy by using time-of-day scheduling, timed override, demand limiting, and chiller sequencing. A building owner can completely monitor the Air-cooled chiller from the Tracer system, since all of the monitoring information indicated on the microcomputer can be read on the unit controllers Tracer system display. In addition, all the powerful diagnostic information can be read back at the Tracer system. Best of all, this powerful capability comes over a single twisted pair of wires! Air-cooled chillers can interface with many different external control systems, from simple stand-alone units to ice-making systems. Each unit requires a single-source, three phases power supply. A single twisted pair of wires tied directly between the Trane chillers and a Tracer Summit™ system provides control, monitoring, and diagnostic capabilities. Control functions include auto/stop, adjustment of leaving-water-temperature set point and control of ice-making mode.

Controls

The Tracer system reads monitoring information such as entering- and leaving-evaporator-water temperatures and air temperature. Over 60 individual diagnostic codes can be read by the Tracer system. In addition, the Tracer system can provide sequencing control for up to 25 units on the same chilled-water loop. Pump sequencing control can be provided from the Tracer system.

Tracer ICS is not available in conjunction with the external set point capability.

Required Options

Tracer Interface

Additional Options that May Be Used

Ice-Making Control

External Trane Devices Required

Tracer Summit™, Tracer 100 System or Tracer Chiller Plant Control

Ice-Making Systems Controls

An ice-making option may be ordered with the air-cooled chiller. The unit will have two operating modes, ice making and normal daytime cooling. In the ice making mode, the air-cooled chiller will operate at full compressor capacity until the return chilled-fluid temperature entering the evaporator meets the ice making set point. Two input signals are required to the air-cooled chiller for the ice-making option. The first is an auto/stop signal for scheduling, and the second is required to switch the unit between the ice-making mode and normal daytime operation. The signals are provided by a remote job site building-automation device such as a time clock or a manual switch. In addition, the signals may be provided over the twisted wire pair from a Tracer™ system, or a LonTalk Communication Interface but will require the communication boards provided with the Ice Making Control Option.

Additional Options That May Be Used

- Failure Indication Contacts Communications Interface (For Tracer Systems)
- Chilled-Water Temperature Reset

General Data

Table 3 - CGCL general data

		CGCL 200 R407C	CGCL 250 R407C	CGCL 300 R407C	CGCL 350 R407C	CGCL 400 R407C	CGCL 450 R407C	CGCL 500 R407C	CGCL 600 R407C
Eurovent Performances (1)									
Net cooling capacity	(kW)	49.2	61.1	74.0	86.9	101.0	111.0	126.0	152.0
Total power input in cooling	(kW)	21.9	26.9	34.6	38.28	46.8	55.5	59.7	73.1
Evaporator water pressure drop	(kPa)	42	41	42	41	39	46	56	68
Main power supply		400/3/50							
Sound power level 300 Pa	(dB(A))	88	84	87	89	91	95	90	94
Sound power level 400 Pa	(dB(A))	90	86	89	90	93	96	92	95
Sound power level 500 Pa	(dB(A))	91	88	90	92	94	97	93	96
Units Amps									
Nominal (4)	(A)	48	61.4	76.7	86.1	102.3	117.7	120.8	151.3
Start-up amps	(A)	150	209	224	234	250	265	268	299
Recommended fuse size (Am)	(A)	Depends on installation							
Max supply cable size	(mm ²)	35	35	50	50	95	95	95	95
Max. wire length	(m)	Depends on installation							
Compressor									
Number (circ 1/ circ 2)		2	2	2	3	3	3	2/2	2/2
Type		Scroll							
Model		10T+10T	10T+15T	2x15T	2x10T+15T	10T+2x15T	3x15T	2x(10T+15T)	4x15T
Number of speeds		1	1	1	1	1	1	1	1
Number of motors		1	1	1	1	1	1	1	1
Rated amps (2)(4)	(A)	37	46	55	65	74	83	92	110
Locked rotor amps (2)	(A)	139	194	203	212	221	230	240	258
Motor RPM	(rpm)	2900	2900	2900	2900	2900	2900	2900	2900
Evaporator									
Number		1							
Type		Brazed plate							
Water volume (total)	(l)	4.7	5.9	7.0	8.2	10.5	10.5	12.3	16.1
Antifreeze Heater	(W)	65	65	65	65	65	65	130	130
Water connection type		Male ISO R7							
Water connection diameter		1"1/2	1"1/2	1"1/2	2"	2"	2"	2"1/2	2"1/2
Coil									
Type		Plate Fin							
Tube size	(mm)	9.52							
Tube type		Smooth							
Height	(mm)	914	1219	1219	1219	1219	1219	1626	1626
Length	(mm)	1829	1829	1829	2743	2743	2743	2743	2743
Face Area	(m ²)	1.67	2.23	2.23	3.34	3.34	3.34	4.46	4.46
Number of rows		4							
Fins per inch (fpf)		180							
Fan									
Type		Centrifugal							
Number		1	2	2	2	2	2	3	3
Diameter		AT 18-18							
Drive type		Belt Drive							
Number of speeds		2							
Number of motors		1							
Dimensions									
Height	(mm)	1997	1997	1997	1997	1997	1997	1997	1997
Length	(mm)	2268	2268	2268	3230	3230	3230	3230	3230
Width	(mm)	866	866	866	866	866	866	1216	1216
Weight uncrated	(kg)	710	830	890	1080	1140	1200	1380	1500
Weight crated	(kg)	750	870	930	1130	1190	1250	1450	1570
Refrigerant circuit data									
Number of circuits		1	1	1	1	1	1	2	2
Refrigerant charge A/B	(kg)	12/-	15/-	15/-	24/-	24/-	24/-	15/15	15/15
Oil charge A/B	(l)	7.6/-	10/-	12.4/-	13.8/-	16.2/-	18.6/-	10/10	12.4/12.4

(1) at Eurovent Conditions at nominal airflow (Evap 12°C/7°C - Air. 35°C)
(2) per motor
(3) per circuit
(4) 5°C saturated suction temperature - 60°C saturated discharge temperature

Condenser Fan Performance

Table 4 - CGCL Fan performance

Size	Airflow (m ³ /h)		Total Fan Static Pressure (Pa)		
			300	400	500
CGCL 200	15300	Fan Motor Nominal Power Low Speed* (kW)	0.75	1.1	1.1
		Fan Motor Nominal Power High Speed (KW)	4.0	5.5	5.5
		Nominal Amps Low speed * (A)	3.2	3.7	3.7
		Nominal Amps High speed (A)	8.9	11	11
		Starting Amps * (A)	14	12	12
CGCL 250	17800	Fan Motor Nominal Power Low Speed* (kW)	0.75	1.1	1.5
		Fan Motor Nominal Power High Speed (KW)	4.0	5.5	7.5
		Nominal Amps Low speed * (A)	3.2	3.7	5.0
		Nominal Amps High speed (A)	8.9	11	15.3
		Starting Amps * (A)	14	12	17
CGCL 300	23800	Fan Motor Nominal Power Low Speed* (kW)	1.5	1.5	2.8
		Fan Motor Nominal Power High Speed (KW)	7.5	7.5	11.0
		Nominal Amps Low speed * (A)	5.0	5.0	7.7
		Nominal Amps High speed (A)	15.3	15.3	21.5
		Starting Amps * (A)	17	17	33
CGCL 350	26800	Fan Motor Nominal Power Low Speed* (kW)	1.5	2.8	2.8
		Fan Motor Nominal Power High Speed (KW)	7.5	11.0	11.0
		Nominal Amps Low speed * (A)	5.0	7.7	7.7
		Nominal Amps High speed (A)	15.3	21.5	21.5
		Starting Amps * (A)	17	33	33
CGCL 400	30600	Fan Motor Nominal Power Low Speed* (kW)	2.8	2.8	3.8
		Fan Motor Nominal Power High Speed (KW)	11	11	15
		Nominal Amps Low speed * (A)	7.7	7.7	10.1
		Nominal Amps High speed (A)	21.5	21.5	28.6
		Starting Amps * (A)	33	33	43
CGCL 450	34500	Fan Motor Nominal Power Low Speed* (kW)	3.8	3.8	4.8
		Fan Motor Nominal Power High Speed (KW)	15.0	15.0	18.5
		Nominal Amps Low speed * (A)	10.1	10.1	12.1
		Nominal Amps High speed (A)	28.6	28.6	34.6
		Starting Amps * (A)	43	43	45
CGCL 500	39100	Fan Motor Nominal Power Low Speed* (kW)	2.8	3.8	3.8
		Fan Motor Nominal Power High Speed (KW)	11.0	15.0	15.0
		Nominal Amps Low speed * (A)	7.7	10.1	10.1
		Nominal Amps High speed (A)	21.5	28.6	28.6
		Starting Amps * (A)	33	43	43
CGCL 600	47600	Fan Motor Nominal Power Low Speed* (kW)	4.8	4.8	5.3
		Fan Motor Nominal Power High Speed (KW)	18.5	18.5	22.0
		Nominal Amps Low speed * (A)	12.1	12.1	13.2
		Nominal Amps High speed (A)	34.9	34.9	40.9
		Starting Amps * (A)	45	45	48

*: Fan motor always start in Low speed

Unit nominal amps = nominal fan amps (according to static pressure) + compressor nominal amps

Unit starting amps = nominal fan amps (according to static pressure) + compressor starting amps

Pressure drop through condenser coil and air filter

Table 5 - Pressure drop

Unit	Airflow m ³ /h	Internal chiller pressure drop (Pa)			
		Cds coil	AR300 filter	A150 Filter	M8 Filter
CGCL 200	15300	96	100	66	28
CGCL 250	17800	77	85	56	22
CGCL 300	23800	124	122	84	40
CGCL 350	26800	77	85	56	22
CGCL 400	30600	96	100	68	28
CGCL 450	34500	117	117	80	36
CGCL 500	39100	124	95	64	26
CGCL 600	47600	163	122	84	40

Available static pressure = Total fan static pressure (from table 4) - Chiller internal pressure drop (from table 5)

IMPORTANT: The setting of the external static pressure supplied by the CGCL chiller must correspond to the actual ductwork (inlet and outlet) pressure drop +/- 50Pa. Failure to comply to this condition could lead to operational problems such as excessive sound levels, vibrations, or early wear of motor, fan or bearings. Adjustment of the airflow through the unit must be performed at chiller commissioning or warranty will not apply.

Selection of the Proper Available Static Pressure:

Static pressure indicated only takes into account the available pressure of the fan. It is necessary to subtract the pressure drop of the components from Table 5. Failure to do so will end up in increasing constraint on the bearings and on the motor which will result in a drastic reduction of the lifespan of the fan.

For example:

CGCL 350

- with 400 Pa available static pressure fans
- with 77 Pa condenser coil
- with A150 Filter of 56 Pa

Available static pressure = 400 Pa - 77 Pa - 56 Pa = 267 Pa

The tolerance is +/- 50 Pa

In this example the pressure drop will have to be between 217 Pa and 317 Pa.

Performance Data

Table 6 - Cooling Capacities CGCL 200

% Ethylene Glycol	Leaving Chilled Water Temp.	Outdoor Ambient Temperature							
		25°C		30°C		35°C		40°C	
		Cap kW	Pl. kW	Cap kW	Pl. kW	Cap kW	Pl. kW	Cap kW	Pl. kW
37	-12°C	27.2	12.0	25.9	13.5	24.4	15.2		
33	-8°C	32.2	12.4	30.6	13.9	28.9	15.7	27.0	17.8
27	-4°C	37.7	12.8	35.8	14.3	33.8	16.2	31.6	18.4
20	0°C	43.6	13.2	41.5	14.9	39.1	16.8	36.6	19.0
10	4°C	49.9	13.7	47.4	15.4	44.8	17.4	42.0	19.7
0	5°C	51.7	13.8	49.2	15.6	46.4	17.6	43.5	19.9
0	6°C	53.2	14.0	50.6	15.7	47.8	17.7	44.8	20.1
0	7°C	54.8	14.1	52.1	15.9	49.2	17.9	46.1	20.2
0	8°C	56.4	14.2	53.6	16.0	50.7	18.1	47.5	20.4
0	9°C	57.9	14.4	55.1	16.1	52.1	18.2	48.8	20.6
0	10°C	59.5	14.5	56.6	16.3	53.5	18.4		
0	11°C	61.1	14.6	58.1	16.4	54.9	18.5		
0	12°C	62.6	14.7	59.6	16.6	56.3	18.7		

Table 7 - Cooling Capacities CGCL 250

% Ethylene Glycol	Leaving Chilled Water Temp.	Outdoor Ambient Temperature							
		25°C		30°C		35°C		40°C	
		Cap kW	Pl. kW	Cap kW	Pl. kW	Cap kW	Pl. kW	Cap kW	Pl. kW
37	-12°C	34.2	15.2	32.5	17.1	30.7	19.2		
33	-8°C	40.4	15.8	38.4	17.7	36.2	19.9	33.9	22.5
27	-4°C	47.2	16.4	44.9	18.3	42.3	20.7	39.6	23.4
20	0°C	54.4	17.0	51.7	19.1	48.9	21.5	45.8	24.2
10	4°C	62.1	17.7	59.1	19.9	55.8	22.4	52.2	25.2
0	5°C	64.3	17.9	61.1	20.1	57.7	22.6	54.1	25.5
0	6°C	66.2	18.1	62.9	20.3	59.4	22.8	55.7	25.7
0	7°C	68.0	18.3	64.7	20.5	61.1	23.1	57.3	26.0
0	8°C	69.9	18.4	66.5	20.7	62.8	23.3		
0	9°C	71.8	18.6	68.3	20.9	64.5	23.5		
0	10°C	73.7	18.8	70.1	21.1	66.2	23.7		
0	11°C	75.6	19.0	71.9	21.3	67.9	24.0		
0	12°C	77.5	19.2	73.7	21.5	69.6	24.2		

Cap = Cooling Capacity

Pl. = Compressor Power Input

Waterflow (l/s) = Cap/(4.18 x Dt), With Dt = Entering - Leaving Water Temperature (°C) and Cap (kW)

Performance Data

Table 8 - Cooling Capacities CGCL 300

% Ethylene Glycol	Leaving Chilled Water Temp.	Outdoor Ambient Temperature							
		25°C		30°C		35°C		40°C	
		Cap kW	P.I. kW	Cap kW	P.I. kW	Cap kW	P.I. kW	Cap kW	P.I. kW
37	-12°C	41.3	18.3	39.2	20.5	37.1	23.1		
33	-8°C	48.8	19.0	46.4	21.2	43.8	23.9	41.2	26.9
27	-4°C	56.9	19.7	54.2	22.0	51.2	24.7	48.1	27.8
20	0°C	65.6	20.4	62.5	22.9	59.1	25.7	55.5	28.8
10	4°C	74.9	21.2	71.3	23.8	67.5	26.7	63.4	29.9
0	5°C	77.5	21.5	73.8	24.0	69.8	26.9	65.6	30.2
0	6°C	79.8	21.7	76.0	24.2	71.9	27.2	67.5	30.5
0	7°C	82.1	21.9	78.2	24.5	74.0	27.4	69.4	30.7
0	8°C	84.4	22.1	80.3	24.7	76.0	27.7	71.4	31.0
0	9°C	86.7	22.3	82.5	24.9	78.1	27.9		
0	10°C	88.9	22.5	84.7	25.2	80.1	28.2		
0	11°C	91.2	22.7	86.8	25.4	82.2	28.4		
0	12°C	93.5	22.9	89.0	25.6	84.2	28.7		

Table 9 - Cooling Capacities CGCL 350

% Ethylene Glycol	Leaving Chilled Water Temp.	Outdoor Ambient Temperature							
		25°C		30°C		35°C		40°C	
		Cap kW	P.I. kW	Cap kW	P.I. kW	Cap kW	P.I. kW	Cap kW	P.I. kW
37	-12°C	48.2	20.9	45.9	23.4	43.3	26.4		
33	-8°C	57.1	21.6	54.3	24.2	51.3	27.2	48.1	31.8
27	-4°C	66.7	22.3	63.5	25.0	60.0	28.1	56.3	31.8
20	0°C	77.0	23.1	73.3	25.9	69.4	29.1	65.1	32.9
10	4°C	88.0	23.9	83.8	26.8	79.3	30.2	74.4	34.1
0	5°C	91.1	24.2	86.8	27.1	82.1	30.5	77.0	34.4
0	6°C	93.8	24.4	89.3	27.3	84.5	30.8	79.3	34.7
0	7°C	96.5	24.6	91.9	27.6	86.9	31.0	81.6	35.0
0	8°C	99.2	24.8	94.5	27.8	89.4	31.3	83.9	35.3
0	9°C	101.9	25.0	97.0	28.1	91.8	31.6	86.2	35.6
0	10°C	104.5	25.3	99.6	28.3	94.2	31.9	88.5	35.9
0	11°C	107.2	25.5	102.1	28.6	96.6	32.1	90.8	36.2
0	12°C	109.9	25.7	104.6	28.8	99.0	32.4		

Cap = Cooling Capacity
P.I. = Compressor Power Input

Waterflow (l/s) = Cap/(4.18 x Dt), With Dt = Entering - Leaving Water Temperature (°C) and Cap (kW)

Performance Data

Table 10 - Cooling Capacities CGCL 400

%	Leaving Ethylene Glycol Chilled Water Temp.	Outdoor Ambient Temperature							
		25 °C		30 °C		35 °C		40 °C	
		Cap kW	P.I. kW	Cap kW	P.I. kW	Cap kW	P.I. kW	Cap kW	P.I. kW
37	-12 °C	56.3	24.3	53.4	27.2	50.4	30.6		
33	-8 °C	66.5	25.1	63.2	28.1	59.7	31.6	56.0	35.6
27	-4 °C	77.8	26.0	74.0	29.1	69.9	32.7	65.5	36.9
20	0 °C	89.8	27.0	85.4	30.2	80.8	33.9	75.7	38.2
10	4 °C	102.5	28.1	97.5	31.4	92.2	35.3	86.5	39.6
0	5 °C	106.0	28.4	100.9	31.8	95.4	35.6	89.5	40.0
0	6 °C	109.2	28.6	103.9	32.1	98.2	36.0	92.1	40.4
0	7 °C	112.3	28.9	106.8	32.4	101.0	36.3	94.8	40.7
0	8 °C	115.4	29.2	109.8	32.7	103.8	36.6	97.4	41.1
0	9 °C	118.5	29.5	112.7	33.0	106.6	37.0	100.0	41.5
0	10 °C	121.6	29.7	115.7	33.3	109.4	37.3		
0	11 °C	124.7	30.0	118.6	33.6	112.1	37.6		
0	12 °C	127.7	30.3	121.5	33.9	114.9	38.0		

Table 11 - Cooling Capacities CGCL 450

%	Leaving Ethylene Glycol Chilled Water Temp.	Outdoor Ambient Temperature							
		25 °C		30 °C		35 °C		40 °C	
		Cap kW	P.I. kW	Cap kW	P.I. kW	Cap kW	P.I. kW	Cap kW	P.I. kW
37	-12 °C	62.4	27.6	59.2	30.8	56.0	34.6		
33	-8 °C	73.6	28.5	70.0	31.9	66.2	35.8	62.2	40.3
27	-4 °C	85.9	29.6	81.7	33.0	77.3	37.1	72.6	41.7
20	0 °C	99.0	30.7	94.2	34.3	89.1	38.5	83.7	43.2
10	4 °C	112.7	31.9	107.3	35.7	101.5	40.0	95.3	44.8
0	5 °C	116.6	32.3	111.0	36.1	105.0	40.4	98.6	45.2
0	6 °C	119.9	32.6	114.2	36.4	108.0	40.7	101.4	45.6
0	7 °C	123.3	32.9	117.3	36.7	111.0	41.1	104.2	46.0
0	8 °C	126.6	33.2	120.5	37.1	114.0	41.5	107.0	46.4
0	9 °C	129.9	33.5	123.6	37.4	117.0	41.9		
0	10 °C	133.2	33.8	126.8	37.8	119.9	42.2		
0	11 °C	136.4	34.1	129.8	38.1	122.8	42.6		
0	12 °C	139.6	34.4	132.9	38.4	125.7	43.0		

Cap = Cooling Capacity
P.I. = Compressor Power Input

Waterflow (l/s) = Cap/(4.18 x Dt), With Dt = Entering - Leaving Water Temperature (°C) and Cap (kW)

Performance Data

Table 12 - Cooling Capacities CGCL 500

%	Leaving Ethylene Glycol Chilled Water Temp.	Outdoor Ambient Temperature							
		25 °C		30 °C		35 °C		40 °C	
		Cap kW	Pl. kW	Cap kW	Pl. kW	Cap kW	Pl. kW	Cap kW	Pl. kW
37	-12 °C	69.2	30.3	65.8	33.9	62.3	38.2		
33	-8 °C	82.0	31.3	78.1	35.0	73.8	39.4	69.3	44.6
27	-4 °C	96.3	32.4	91.6	36.3	86.7	40.9	81.4	46.1
20	0 °C	111.5	33.6	106.2	37.7	100.5	42.4	94.3	47.8
10	4 °C	127.5	34.9	121.4	39.1	115.0	44.0	108.0	49.5
0	5 °C	132.0	35.3	125.8	39.6	119.1	44.5	111.8	50.0
0	6 °C	135.8	35.6	129.4	39.9	122.5	44.9	115.1	50.5
0	7 °C	139.7	35.9	133.1	40.3	126.0	45.3	118.4	50.9
0	8 °C	143.5	36.3	136.7	40.7	129.5	45.7	121.7	51.3
0	9 °C	147.3	36.6	140.3	41.0	132.9	46.1	124.9	51.8
0	10 °C	151.1	36.9	143.9	41.4	136.3	46.5		
0	11 °C	154.8	37.3	147.5	41.7	139.6	46.9		
0	12 °C	158.5	37.6	151.0	42.1	142.9	47.3		

Table 13 - Cooling Capacities CGCL 600

%	Leaving Ethylene Glycol Chilled Water Temp.	Outdoor Ambient Temperature							
		25 °C		30 °C		35 °C		40 °C	
		Cap kW	Pl. kW	Cap kW	Pl. kW	Cap kW	Pl. kW	Cap kW	Pl. kW
37	-12 °C	84.7	37.0	80.5	41.4	76.1	46.5		
33	-8 °C	100.3	38.3	95.4	42.9	90.2	48.1	84.8	54.2
27	-4 °C	117.4	39.8	111.7	44.5	105.7	49.9	99.4	56.1
20	0 °C	135.6	41.3	129.1	46.2	122.2	51.8	114.8	58.2
10	4 °C	154.5	43.0	147.1	48.1	139.3	53.8	130.8	60.3
0	5 °C	159.8	43.5	152.2	48.6	144.0	54.4	135.3	60.9
0	6 °C	164.3	43.9	156.4	49.0	148.0	54.9	139.1	61.4
0	7 °C	168.7	44.3	160.6	49.5	152.0	55.4	142.8	62.0
0	8 °C	173.0	44.7	164.8	49.9	155.9	55.9		
0	9 °C	177.4	45.1	168.9	50.4	159.8	56.3		
0	10 °C	181.6	45.5	172.9	50.8	163.6	56.8		
0	11 °C	185.7	45.9	176.8	51.2	167.3	57.3		
0	12 °C	189.7	46.3	180.6	51.7	170.9	57.7		

Cap = Cooling Capacity
Pl. = Compressor Power Input

Waterflow (l/s) = Cap/(4.18 x Dt), With Dt = Entering - Leaving Water Temperature (°C) and Cap (kW)



Performance Data

Table 14 - Evaporator Pressure Drop

P.D. (kPa)	Water flow (l/s)							
	CGCL 200	CGCL 250	CGCL 300	CGCL 350	CGCL 400	CGCL 450	CGCL 500	CGCL 600
10	1.155	1.449	1.736	1.912	2.282	2.282	2.500	2.700
20	1.631	2.045	2.447	2.809	3.343	3.343	3.561	3.853
40	2.301	2.886	3.448	4.129	4.898	4.898	5.074	5.499
60	2.815	3.530	4.215	5.172	6.125	6.125	6.241	6.771
80	3.248	4.072	4.860	6.068	7.177	7.177	7.228	7.848
100	3.629	4.550	5.427	6.868	8.116	8.116	8.100	8.800

Selection with ethylene glycol

When ethylene glycol is added in the chilled water circuit the following adjustment factors have to be taken in account.

Table 15 - Ethylene glycol adjustment factors

LWTE	PCT EG (%)	Adjustment factors			
		Flow rate	Pressure drop	Power Input	Cooling Cap.
12	30	1.11	1.20	1.005	0.98
5	30	1.11	1.24	1.005	0.98
4	10	1.02	1.08	-	-
0	20	1.05	1.19	-	-
-4	27	1.08	1.29	-	-
-8	33	1.10	1.46	-	-
-12	37	1.12	1.62	-	-

Mechanical Specifications

Cooling only chillers - CGCL

General

Units shall be assembled on heavy gauge steel mounting/lifting rails and shall be weather proofed. Unit shall include scroll compressors, plate fin condenser coil, brazed plate heat exchangers fans and motors, controls and operating charge of R407C refrigerant. Operating Range shall be between - 5°C and + 40°C in cooling as standard.

Casing

Unit casing shall be constructed of galvanized steel. Exterior surfaces shall be cleaned, phosphatized and finished with a weather-resistant textured polyester powder paint. Units surface shall be tested 500 hours in salt spray test. Units shall have removable end panels which allow access to all major components and controls.

Refrigeration System - Single Circuit

CGCL 200, 250, 300, 350, 400 and 450 units shall have a single refrigeration circuit. Each refrigeration circuit has an integral subcooling circuit. A refrigerant filter drier, expansion valve and check valves shall be provided as standard. Units shall have both a liquid line and suction gas line with gauge port. The refrigeration circuit is controlled by one thermostatic expansion valve.

CGCL 200, 250, 300, 350, 400 and 450 units shall have scroll compressors with centrifugal oil pump providing positive lubrication to moving parts. Motor shall be suction gas-cooled and shall have a voltage utilization range of plus or minus 10 percent of nameplate voltage. Temperature and current-sensitive motor overloads shall be included for maximum protection.

Refrigeration System - Dual Circuit

CGCL500 and 600 units shall have two separate and independent refrigeration circuits. Each refrigeration circuit shall have an integral subcooling circuit. A refrigerant filter drier shall be provided as standard. Units shall have both a liquid line and suction gas line with gauge ports. Each refrigeration circuit is controlled by one thermostatic expansion valve. CGCL500 and 600 units shall have scroll compressors with centrifugal oil pump and provide positive lubrication to all moving parts. Motor shall be suction gas-cooled and shall have a voltage utilization range of plus or minus 10 percent of nameplate voltage. Internal temperature and current-sensitive motor overloads shall be included for maximum protection. The refrigeration circuit is controlled by two thermostatic expansion valve.

Condenser Coil

Coils shall be smooth bore 9.52 mm copper tubes mechanically bonded to configured aluminum plate fin as standard. Coil shall be factory pressure and leak tested to 30 bar air pressure.

Evaporator

Shall be of the stainless steel brazed plates type. Evaporator shall include thermal insulation and anti-freeze protection. A differential pressostat shall ensure the water flow control.

Condenser Fan And Motor(s)

Forward inclined blades centrifugal fan, statically and dynamically balanced, providing a static pressure up to 500 Pa. Flexible duct between fan outlet and connection flange. Vertical or horizontal discharge, front or rear side of the unit. Life lubricated ball bearing, 1500 RPM motor, IP44 type with integrated thermal protection. Mechanical belt tension system.

Controls

Units shall be completely factory wired with microprocessor based control and contactor pressure lugs or terminal block for power wiring. Control wiring shall be 230V-volt /27 Volt control circuit which includes fusing and control transformer. Units shall include a fused disconnect device. Microprocessor shall control leaving and entering water temperature, operating parameters, anti-short cycling, and anti-freeze protection of the evaporator. The liquid crystal display shall indicate leaving water temperature and any fault in full text in the country language. Dry contacts shall be available for remote signalling of operating modes and general faults.



Literature Order Number	CG-PRC009-E4
Date	0406
Supersedes	CG-PRC009-E4_0601
Stocking Location	Europe

Trane has a policy of continuous product and product data improvement and reserves the right to change design and specifications without notice.

www.trane.com

For more information, contact your local sales office or e-mail us at comfort@trane.com

American Standard Europe BVBA
Registered Office: 1789 Chaussée de Wavre, 1160 Brussels - Belgium